

19" Free Standing Cabinet / UNIVERSALLINE 600x1000 mm



FEATURES

Easy to access

Front door features a full-length smoked and shatterproof glass door with decorative accent trim reinforced with left/right metal frames and integral locking mechanism.

Side doors; lockable, removable complete with slam latches and locks.

Rear door; lockable, removable with lock.

Secure, locking front and back doors with spring loaded hinges offer best accessibility even when connecting the cabinets. The door hinge is easily swapped from one side to the other.

All giving you 4-way access to equipment. Front and rear door can be replaced that gives you flexibility for different installations.

*Cable access

Multiple cable entry points provide maximum versatility. There is a rubber edge sliding cover mechanism that protects and fix the cables.

There is a brush on the rear panel that can be positioned on top or bottom (brush entry available on racks of 32U and above)

*Construction

Rigid welded frame construction in steel sheet, rapidly dismantled per 4 screw per corner. Corner of bases have welded sockets on each corner that tightly fixed into the columns gives maximum stability.

Frames are made with 28-fold design for increased stability.

C-rails (3ea.left+3ea.right) increase the stability of equipment mounting and fixing shelves in 4 points.

Vented Pagoda-style top cover with built-in space for available top mount cooling system providing protection against dust flow from the top. Besides that it cause a chimney effect to provide passive heat transportation via convection.

19" mounting angles (front/2ea. and back/2ea) allow for flexible configuration and adjustable in depth.

Levelling feet is included as a standard feature.

Extensive range of accessories.

STANDARDS

ISO 9001:2000

TSE:EN 61587-1 Mechanical Structures For Electronic Equipment - Tests For IEC 60917 And IEC 60297

Climatic and Environment: EN 61587-1/4.2, IEC60068-2-1, IEC60068-2-2, IEC60068-2-30,

Static Mechanical Load Lifting: EN61587-1/5.2.1

Static Mechanical Load Stiffness: EN61587-1/5.2.2

Dynamic Mechanical Load Vibration and Shock, Impact:

EN61587-1/5.3.1, EN61587-1/5.3.3, IEC60068-2-6, IEC60068-2-27,

Earth Bond: EN61587-1/6.2

Flammability: EN61587-1/6.3

Degrees Of Protection Provided By Enclosures (Ip Code):

IP20 or IP55, EN61587-1/6.4

COMPLIANCES

UL and cUL

Load Carrying Capacity: 600 kg

Surface Treatment: Fosfat coating

Painting: Ral7035 / Ral9005

Material Definition and Properties, Thicknesses and Shipment Configuration

Part Definition	Material thickness	Material definition & properties	Shipment Configuration
Upper Case	1,5 mm	DIN EN 10130 - 99 EREGLI DC-01 6112 CRS	1ea.
Bottom Case	1,5 mm	DIN EN 10130 - 99 EREGLI DC-01 6112 CRS	1ea.
Front Door	1,5 mm	DIN EN 10130 - 99 EREGLI DC-01 6112 CRS & 4mm SECURE AND TEMPERED GLASS AND LOCK	1ea.
19" mounting angles	1,5 mm	DIN EN 10130 - 99 EREGLI DC-01 6112 & GALVANIZED COATING	4ea. (2ea. at front , 2ea. at rear)
Rear Door	1,2 mm	DIN EN 10130 - 99 EREGLI DC-01 6112 CRS	1ea.
Frame	1,5 mm	DIN EN 10130 - 99 EREGLI DC-01 7122 CRS	4ea.
Side Panel Supports	1,5 mm	DIN EN 10130 - 99 EREGLI DC-01 6112 CRS	2ea.
C-rails	1,5 mm	DIN EN 10130 - 99 EREGLI DC-01 6112 & GALVANIZED COATING	6ea.
Fan Tray (unloaded)	1,5 mm	DIN EN 10130 - 99 EREGLI DC-01 6112 CRS	1ea.
Side Doors	1 mm	DIN EN 10130 - 99 EREGLI DC-01 7122 CRS	2ea.
Top Cover	1 mm	DIN EN 10130 - 99 EREGLI DC-01 6112 CRS	1ea.

19" ESTAP Universalline Cabinets and Racks 600x1000mm

TECHNICAL DRAWINGS

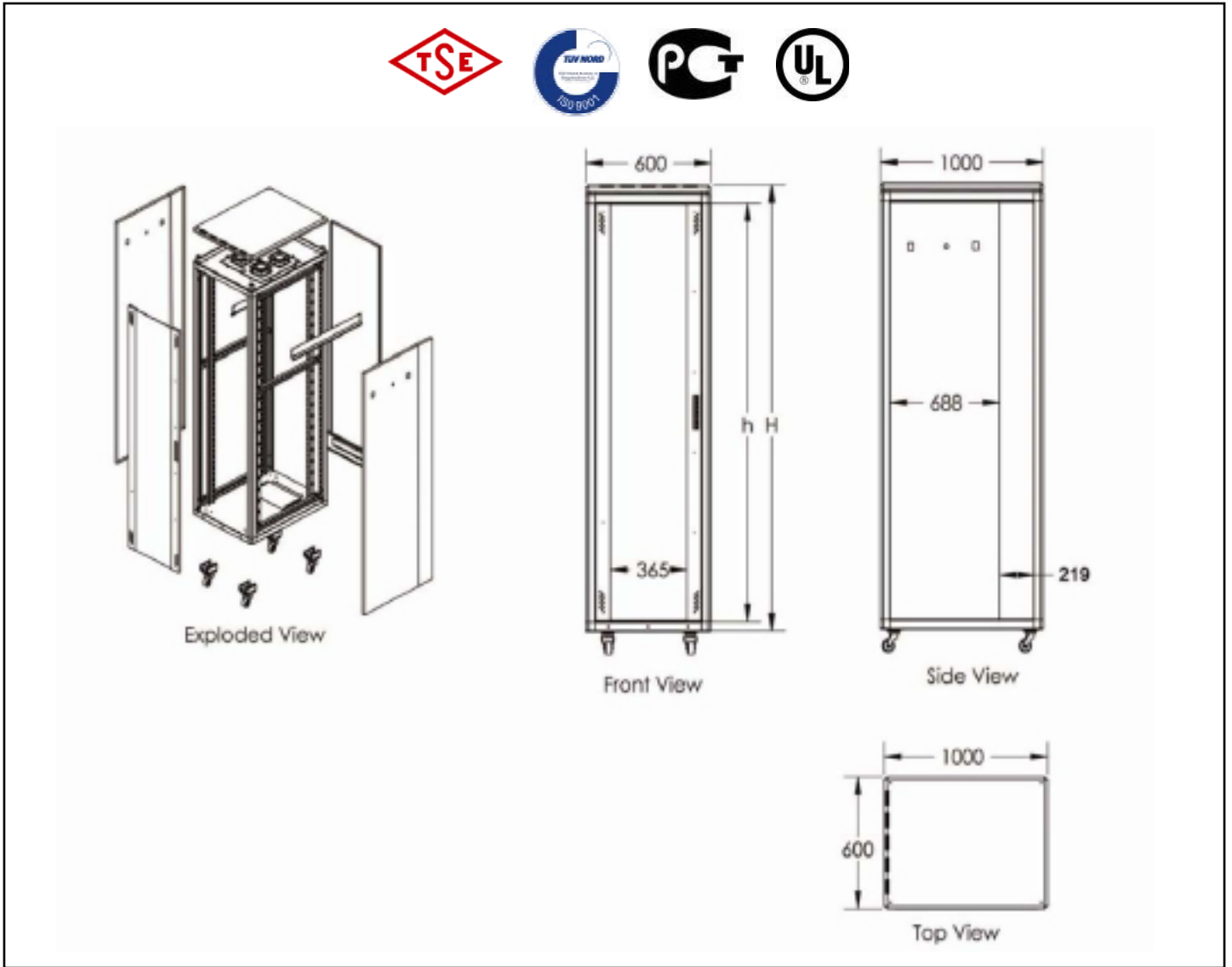

19" Free Standing cabinets width=600 mm depth=1000mm			
Order No	U =44.45 (mm)	h = inside height(mm)	H = outside height(mm)
CKR26U6100	26	1184,40	1309,40
CKR36U6100	36	1629,40	1754,40
CKR42U6100	42	1896,40	2021,40
CKR47U6100	47	2118,75	2243,75

Shipping Data						
Order No	Quantity	Shipping Dimension (palette) WxDxH	Net Weight (kg)	Gross Weight (kg)	Shipping configuration depth (mm)	Max 19" depth
CKR26U6100	1	680x1070x1440	82,60	93,80	740	
CKR36U6100	1	680x1070x1880	103,60	117,80	740	
CKR42U6100	1	680x1070x2160	113,80	127,80	740	
CKR47U6100	1	680x1070x2380	125,00	138,00	740	