

## 19" Wall Mounting Cabinets / PROLINE 600x450 mm/600x560 mm



### FEATURES

#### Easy to access

Front door features a full-length smoked and shatterproof glass door with decorative accent trim reinforced with left/right metal frames and integral locking mechanism.

Side doors; lockable, removable complete with a locks.

Rear door; mechanically lockable, removable it is used as mounting plate at the same time. When mounting the enclosure, rear door is removed and mounted directly to wall and enclosure plug-in to the rear door. It's benefits that, straight on wall, fast installation, low manpower, save time and cost-effective solution. All giving you 4-way access to equipment.

#### Cable access

Multiple cable entry points on top (1ea) and bottom(1ea), provide maximum versatility.

There is a rubberedge sliding cover mechanism that protects and fix the cables. On the rear door, there is also a cable entry hole closed with cover.

When it is used, it is replaced with on of top/bottom rubber edge sliding cover mechanism.

#### Construction

Rigid welded frame construction is in steel sheet. Corner of bases have welded sockets on each corner that tightly fixed into the columns gives maximum stability.

Frames are made with 24-fold design for increased stability.

Vented top cover provide passive heat transportation via convection. There are vented fan holes suitable for cooling unit. (see accessories) 19" mounting angles (front/2ea.) allow for flexible configuration and adjustable in depth.

Extensive range of accessories

Front door features a full-length smoked and shatterproof glass door with decorative accent trim reinforced with left/right metal frames and integral locking mechanism.

Side doors; lockable, removable complete with a locks.

Rear door; mechanically lockable, removable it is used as mounting plate at the same time. When mounting the enclosure, rear door is removed and mounted directly to wall and enclosure plug-in to the rear door. It's benefits that, straight on wall, fast installation, low manpower, save time and cost-effective solution. All giving you 4-way access to equipment.

### STANDARDS

ISO 9001:2000

TSE:EN 61587-1 Mechanical Structures For Electronic Equipment - Tests For IEC 60917 And IEC 60297

Climatic and Environment: EN 61587-1/4.2, IEC60068-2-1, IEC60068-2-2, IEC60068-2-30,

**Static Mechanical Load Lifting:** EN61587-1/5.2.1

**Static Mechanical Load Stiffness:** EN61587-1/5.2.2

**Dynamic Mechanical Load Vibration and Shock, Impact:**

EN61587-1/5.3.1, EN61587-1/5.3.3, IEC60068-2-6,

IEC60068-2-27,

**Earth Bond:** EN61587-1/6.2

**Flammability:** EN61587-1/6.3

**Degrees Of Protection Provided By Enclosures (Ip Code):**

IP20 or IP55, EN61587-1/6.4

### COMPLIANCES

UL and cUL

**Load Carrying Capacity:** 80 kg

**Surface Treatment:** Fosfat coating

**Painting:** Ral7035 / Ral9005

Material Definition and Properties, Thicknesses and Shipment Configuration

Part Definition	Material thickness	Material definition & properties	Shipment Configuration
Upper Case	1,5 mm	DIN EN 10130 - 99 EREGLI DC-01 6112 CRS	1ea.
Bottom Case	1,5 mm	DIN EN 10130 - 99 EREGLI DC-01 6112 CRS	1ea.
Front Door	1,5 mm	DIN EN 10130 - 99 EREGLI DC-01 6112 CRS & 4mm SECURE AND TEMPERED GLASS AND LOCK	1ea.
19" mounting angles	1,5 mm	DIN EN 10130 - 99 EREGLI DC-01 6112 & GALVANIZED COATING	4ea. ( 2ea. at front , 2ea. at rear )
Rear Door	1,5 mm	DIN EN 10130 - 99 EREGLI DC-01 6112 CRS	1ea.
Frame	1,2 mm	DIN EN 10130 - 99 EREGLI DC-01 7122 CRS	4ea.
Fan Tray (unloaded)	1 mm	DIN EN 10130 - 99 EREGLI DC-01 6112 CRS	1ea.
Side Doors	1 mm	DIN EN 10130 - 99 EREGLI DC-01 7122 CRS	2ea.

# 19" Wall Mounting Cabinet / Proline

## TECHNICAL DRAWINGS

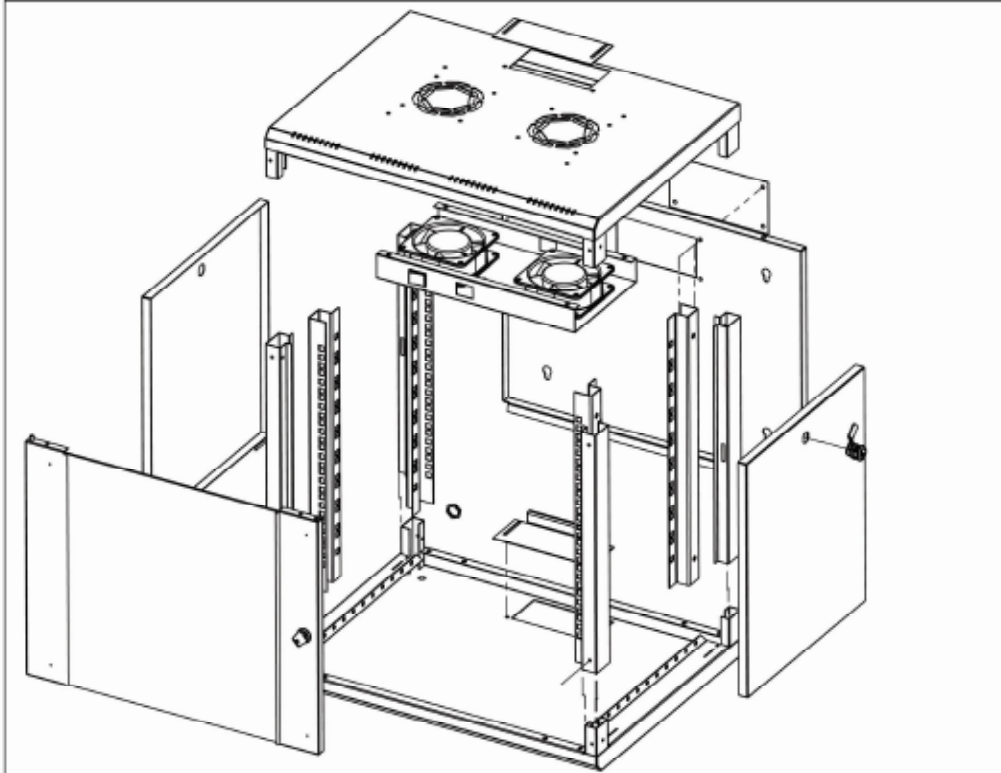

Explode View

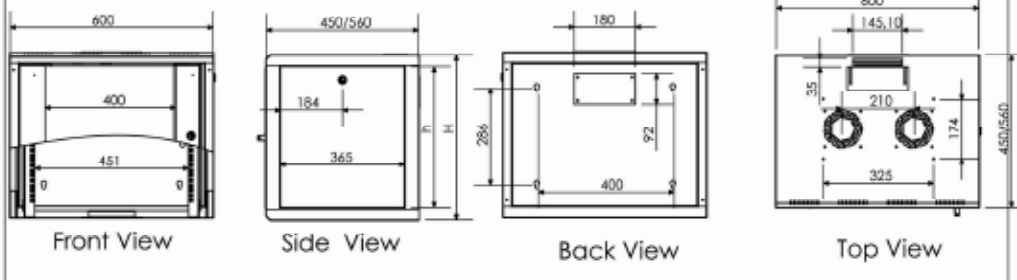

19" Wall Mounting Cabinets / PROLINE width=600mm depth=450 mm			
Order No	U=44.45 (mm)	h = inside height(mm)	H =outside height(mm)
PRL07U45	7	333	402
PRL09U45	9	422	491
PRL12U45	12	555	624
PRL16U45	16	733	802
PRL20U45	20	911	980

Shipping Data						
Order No	Quantity	Shipping Dimension (palette) WxDxH	Net Weight (kg)	Gross Weight (kg)	Shipping configuration depth (mm)	Max 19" depth
PRL07U45	20	1320x1020x2470	392,00	454,00		320
PRL09U45	16	1320x1020x2380	380,00	440,00		320
PRL12U45	12	1320x1020x2295	342,40	394,40		320
PRL16U45	10	1320x1020x2402	300,00	346,40		320
PRL20U45	8	1320x1020x2232	294,00	340,00		320

# 19" Wall Mounting Cabinet / Proline

## TECHNICAL DRAWINGS

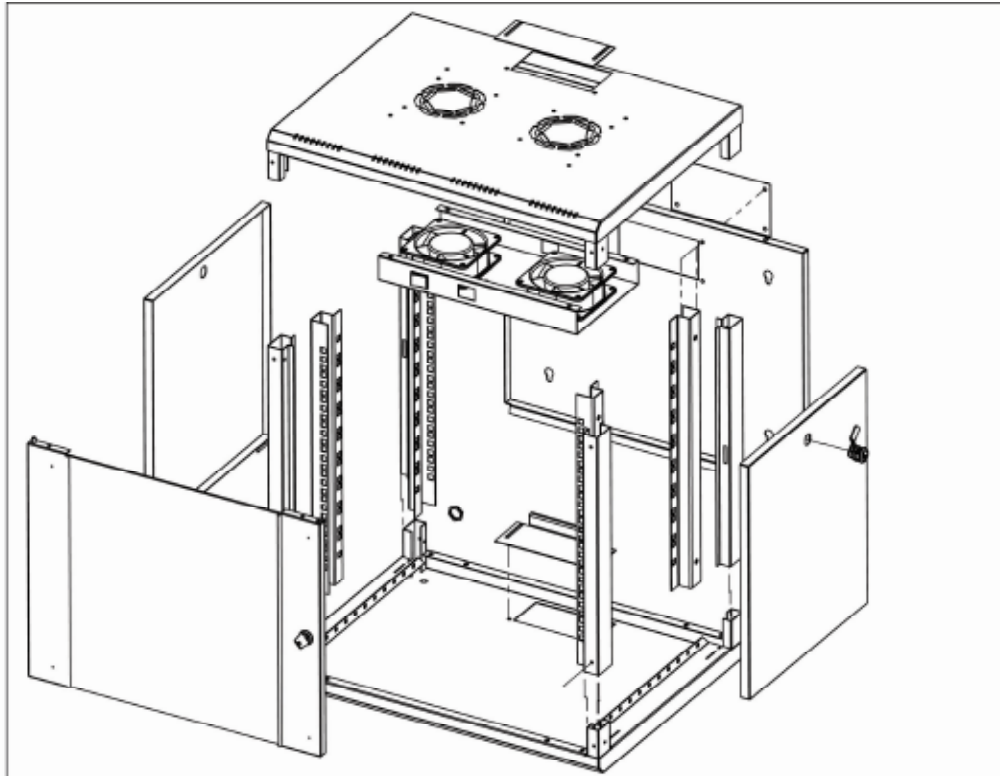

Explode View

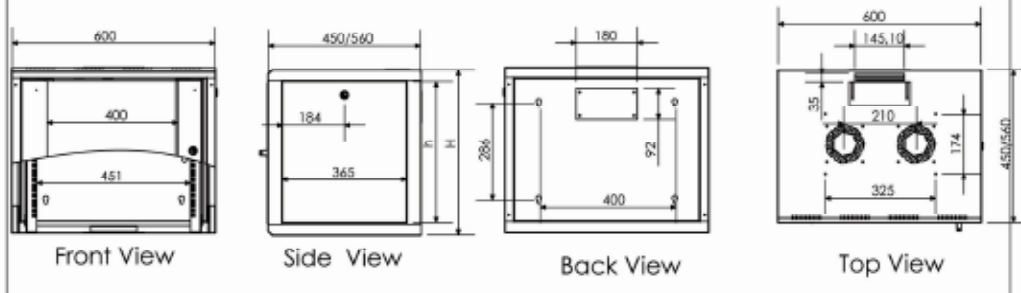

19" Wall Mounting Cabinets / PROLINE width=600 mm depth=560mm			
Order No	U=44.45 (mm)	h = inside height(mm)	H = outside height(mm)
PRL07U56	7	333	402
PRL09U56	9	422	491
PRL12U56	12	555	624
PRL16U56	16	733	802
PRL20U45	20	911	980

Shipping Data						
Order No	Quantity	Shipping Dimension (palette) WxDxH	Net Weight (kg)	Gross Weight (kg)	Shipping configuration depth (mm)	Max 19" depth
PRL07U56	20	1320x1020x2470	440,00	500,00	83	475
PRL09U56	16	1320x1020x2380	390,40	452,00	83	475
PRL12U56	12	1320x1020x2295	338,40	380,00	83	475
PRL16U56	10	1320x1020x2402	332,00	382,00	83	475
PRL20U45	8	1320x1020x2232	304,00	356,00	83	475