

## Electrical Distribution Panel

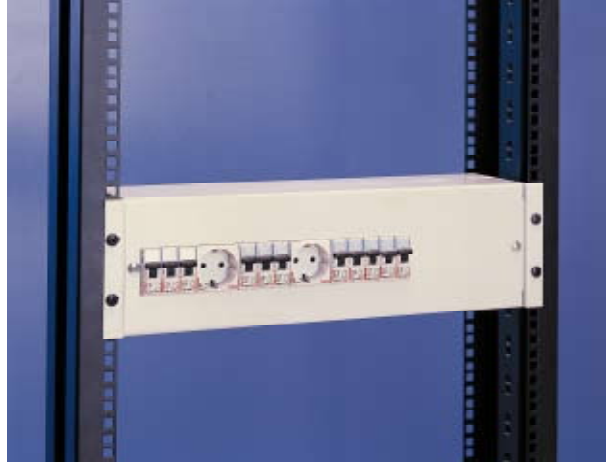

### FEATURES

3U 19" distribution panel c/w neutral and grounding busbar, automatic fuses holder profile rail, cable support rail, cable fixings. Designed for electrical distribution in cabinet for both 220vac and 48vdc. Possible to use 21 circuit breaker or 8ea. 45x45 rail mounted receptacles or their combinations.

### COMPLIANCES

UL and cUL

**Surface Treatment:** Fosfat coating

**Painting:** Ral7035 / Ral9005

### STANDARDS

ISO 9001:2000

TSE:EN 61587-1 Mechanical Structures For Electronic Equipment - Tests For IEC 60917 And IEC 60297

**Climatic and Environment:** EN 61587-1/4.2, IEC60068-2-1, IEC60068-2-2, IEC60068-2-30,

**Earth Bond:**EN61587-1/6.2

**Flammability:** EN61587-1/6.3

Material Definition and Properties, Thicknesses and Shipment Configuration

Part Definition	Material thickness	Material definition & properties	Shipment Configuration
Front Panel	1,20 mm	DIN EN 10130 - 99 EREGLI DC-01 6112 CRS	1 ea.
Main Body	1,50 mm	DIN EN 10130 - 99 EREGLI DC-01 6112 CRS	1 ea.
Front Panel Label	1,00 mm	DIN EN 10130 - 99 EREGLI DC-01 6112 CRS	1 ea.

# Electrical Distribution Panel

## TECHNICAL DRAWINGS

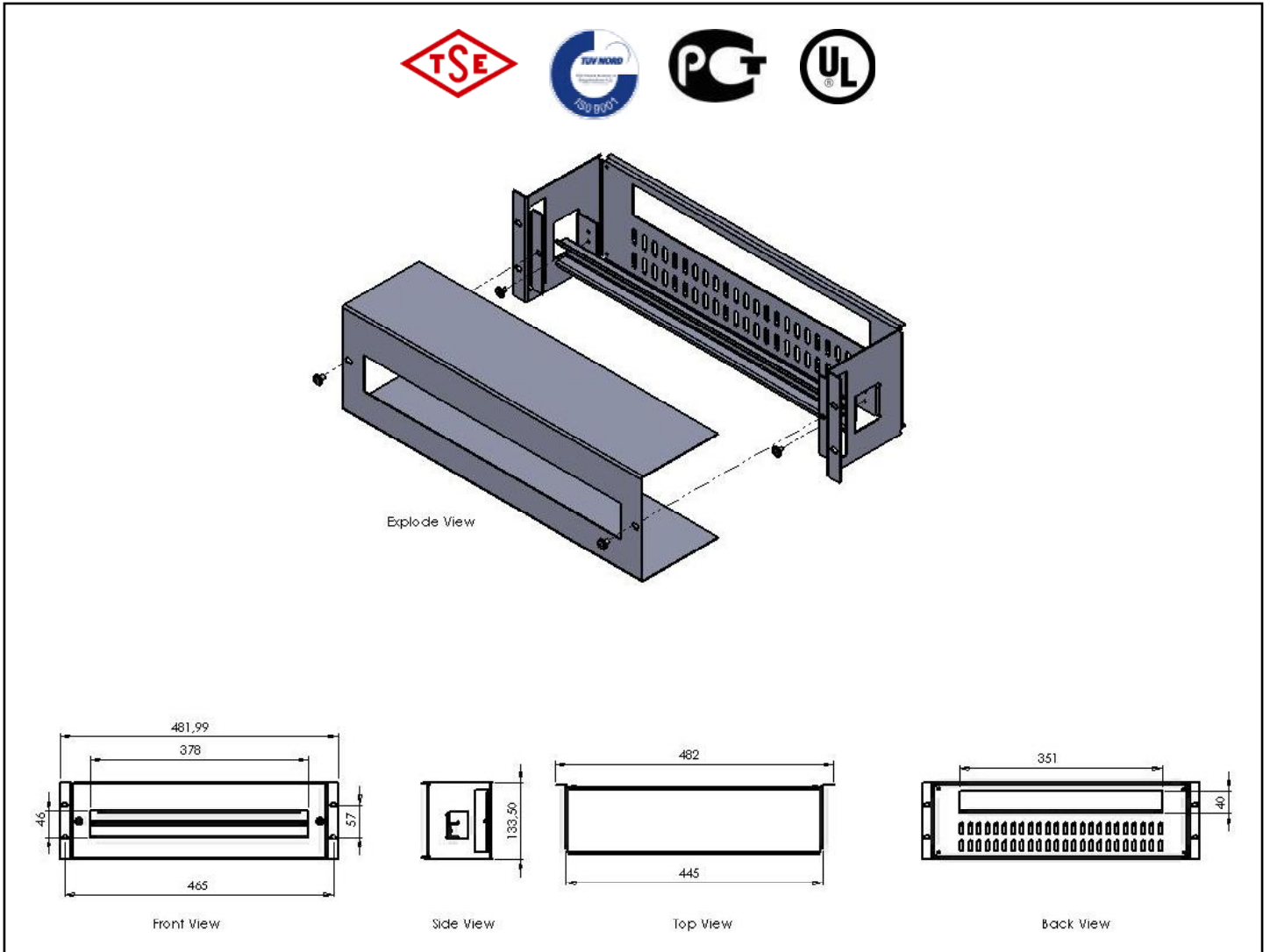

Electrical Distribution Panel		
Order No	Product Definition	Dimensions (wxdxh) mm
M68DCD3U	3U 19" electrical distribution panel	483x150x139